

Catwalks

A multi-level catwalk allows you to expand upward, not outward

- One piece upright posts
- Boltless construction
- Shelves adjustable on 1 1/2" centers
- Access to all storage levels
- Rigid connections provide solid support for decking
- Unit widths up to 72"
- APH posts — "The Strongest in the Industry"
- Designed to meet individual requirements
- Specially designed and engineered to comply with seismic zones and local building codes. Consult your Rapid Rack representative for assistance.

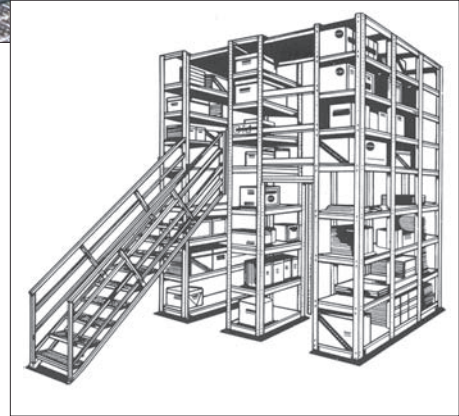

Catwalk design considerations

For preliminary design of a catwalk system the following must be considered:

- Adequate height
- Shelf sizes and capacity
- Number of shelves per unit aisles
- Catwalk loads
- Stairway access
- Obstructions (columns)

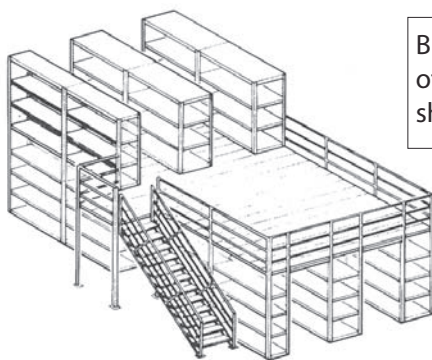

Bulk Rack Design provides wider spans of uninterrupted storage with greater shelf weight capabilities.

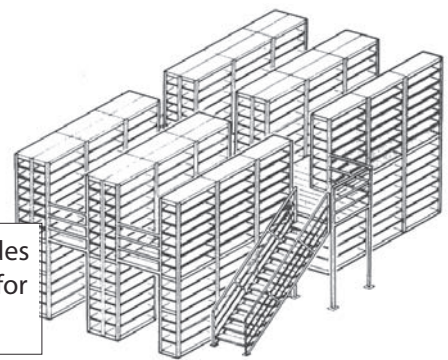

Space Saver Design provides multiple shelf levels ideal for small parts storage.

Stairways

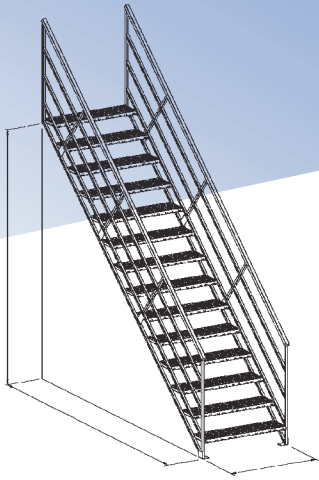

Easy access to upper levels — sturdy and easy to install

- Handrails of welded construction
- Easy to install
- Non-skid treads
- Available in various sizes
- Includes mounting bracket and hardware
- Seismic and non-seismic available upon request.

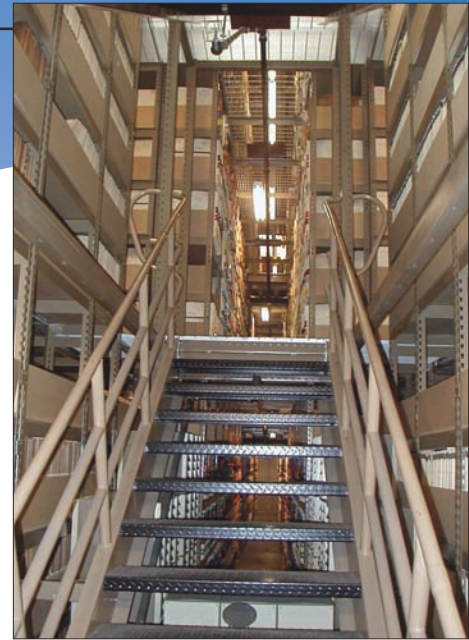

Contact your local Rapid Rack representative for building code application

RapidGrate Steel Decking

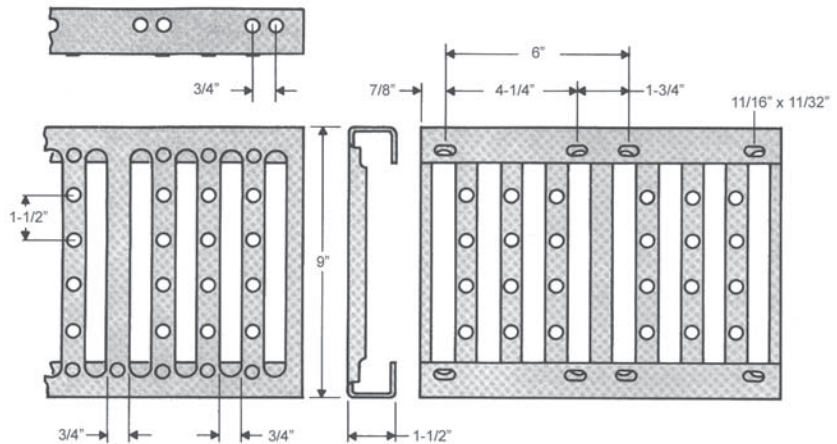

Notes:
 1) In all cases a minimum safety factor of 2 has been used.
 2) Deflections at rated load do not exceed L/240 of unsupported span.

Traction and durability

- Maintenance Free
- Non-Skid Surface
- Applications
 - Mezzanine Decks
 - Catwalks
 - StairTreads
 - Platforms

Specifications

Material: 16 gauge galvanized steel
Weight: 2.6 pounds per running foot
Mounting: Holes for 5/16" bolts at 6" increments in both vertical and horizontal flanges allows for a variety of fastening methods
Dimensions: Width: 9"
 Height: 1 1/2"
 Lengths: 30", 36", 42", 48", 60", 120", 144"
 Special lengths available on request. Consult your Rapid Rack Factory Representative.

Capacities

Description	Unsupported span		
	36"	48"	60"
Concentrated point load*	380 lbs.	300 lbs.	240 lbs.
Distributed Load	800 lbs.	530 lbs.	330 lbs.
Equivalent unit load	350 lbs. per sq.ft.	180 lbs. per sq.ft.	90 lbs. per sq. ft.

* Concentrated point load means a load concentrated on an area no less than 6" square