



PT 55

Hand Pallet Jack

Intra Storage Systems
 5555 McFadden Avenue
 Huntington Beach, CA 92649
 714-895-5128
 info@intrastoragesystems.com



CAPACITY
 5500 lbs.

WEIGHT
 165 lbs

WHEELS / TIRES
 STEER—STEEL HUB
 (2)6.9" x 2.4" polyurethane
 LOAD—STEEL HUB
 (2)2.9" x 3.9" polyurethane

HYDRAULICS
 Three position hydraulic lever: Lifting, neutral, and lowering. Variable speed lowering helps reduce product damage. Fully sealed hydraulic pump with hardened chrome plated lifting piston. Handle return spring, returns handle to vertical position for safe operation.

FRAME
 Tapered fork tip with phenolic "pallet" entry wheels. Steel exit rollers with solid pull rods. 2.9" lowered height—allows handling of virtually any pallet. Reinforced C-channel construction helps resist twisting during heavy loads. Durable powder coat paint.

WARRANTY
 6-months on frame and pump. 90-Days on wheels, axles, bearings and bushings.

OPTIONAL
 Fork Widths: 21"
 Fork Lengths: 36" & 42"

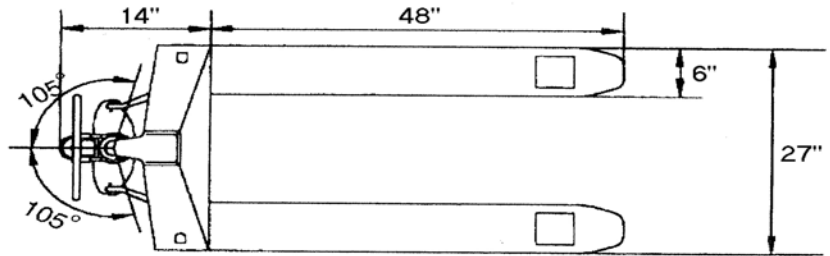

STANDARD SPECIFICATIONS	
Load Capacity:	5500 Lbs.
Lowered Height:	2.9"
Raised Height:	7.2"
Overall Fork Width:	27"
Fork Length:	48"
Between Forks:	15"
Fork Width:	6"
Load Wheels:	(2)2.9" x 3.9"
Steer Wheels:	(2)6.9" x 2.4"
Steering Arc:	210°

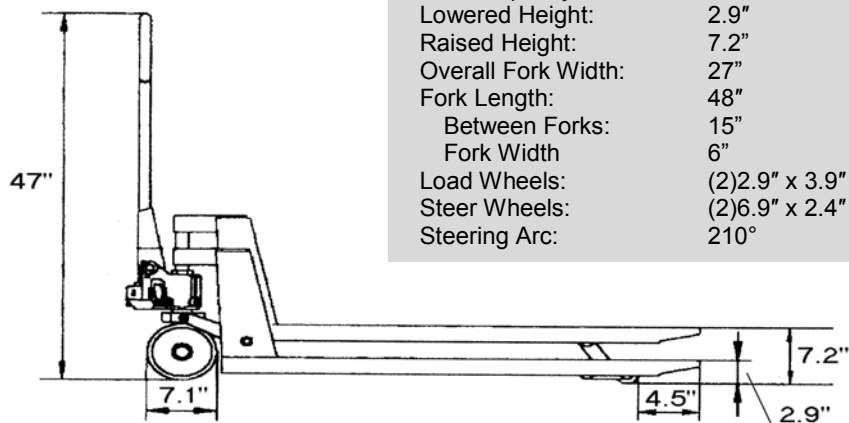

Not... Your ...Average...Joe

Big Joe Manufacturing Company, Inc.
 1700 Higgins Road Suite 200
 Des Plaines, IL 60018
 Phone: 847-298-9800
 Fax: 847-298-6362
 www.bigjoemfg.com

Certification
 All units are built to be in compliance with the Occupational Safety & Health Act (OSHA)
 Big Joe Manufacturing Company will not assume liability for injuries or damage arising from, or caused by, the removal of any safety devices from their vehicles by user. Because of the Big Joe Policy of continuing product improvements, specifications are subject to change without notice.
 © Copyright 2007, Big Joe Manufacturing Company, Des Plaines, IL 60018 Printed USA 0607